

SONY[®]



Camera Control Unit

Operating Instructions

Before operating the unit, please read this manual thoroughly and retain it for future reference.

You can find the operating instructions in Japanese, English, French, German and Italian on the CD-ROM (packed together).
For details on the manuals supplied, see "Using the CD-ROM Manual" on page 6.



CCU-TX50/50P

WARNING

To prevent fire or shock hazard, do not expose the unit to rain or moisture.

To avoid electrical shock, do not open the cabinet. Refer servicing to qualified personnel only.

THIS APPARATUS MUST BE EARTHED.



This symbol is intended to alert the user to the presence of important operating and maintenance (servicing) instructions in the literature accompanying the appliance.

For the customers in the USA (for CCU-TX50)

This equipment has been tested and found to comply with the limits for a Class A digital device, pursuant to Part 15 of the FCC Rules. These limits are designed to provide reasonable protection against harmful interference when the equipment is operated in a commercial environment. This equipment generates, uses, and can radiate radio frequency energy and, if not installed and used in accordance with the instruction manual, may cause harmful interference to radio communications. Operation of this equipment in a residential area is likely to cause harmful interference in which case the user will be required to correct the interference at his own expense.

You are cautioned that any changes or modifications not expressly approved in this manual could void your authority to operate this equipment.

The shielded interface cable recommended in this manual must be used with this equipment in order to comply with the limits for a digital device pursuant to Subpart B of Part 15 of FCC Rules.

WARNING: THIS WARNING IS APPLICABLE FOR USA ONLY.

Using this unit at a voltage other than 120V may require the use of a different line cord or attachment plug, or both. To reduce the risk of fire or electric shock, refer servicing to qualified service personnel.

For the customers in Europe (for CCU-TX50P)

This product with the CE marking complies with both the EMC Directive (89/336/EEC) and the Low Voltage Directive (73/23/EEC) issued by the Commission of the European Community.

Compliance with these directives implies conformity to the following European standards:

- EN60950: Product Safety
- EN55103-1: Electromagnetic Interference (Emission)
- EN55103-2: Electromagnetic Susceptibility (Immunity)

This product is intended for use in the following Electromagnetic Environment (s):

E1 (residential), E2 (commercial and light industrial), E3 (urban outdoors) and E4 (controlled EMC environment, ex. TV studio).

AVERTISSEMENT

Afin d'éviter tout risque d'incendie ou d'électrocution, n'exposez pas cet appareil à la pluie ou à l'humidité.

Afin d'éviter tout risque d'électrocution, n'ouvrez pas le châssis. Confiez l'entretien de cet appareil exclusivement à un personnel qualifié.

CET APPAREIL DOIT ÊTRE RELIÉ LA TERRE.

Pour les clients européens (pour le CCU-TX50P)

Ce produit portant la marque CE est conforme à la fois à la Directive sur la compatibilité électromagnétique (EMC) (89/336/CEE) et à la Directive sur les basses tensions (73/23/CEE) émises par la Commission de la Communauté européenne.

La conformité à ces directives implique la conformité aux normes européennes suivantes :

- EN60950 : Sécurité des produits
- EN55103-1 : Interférences électromagnétiques (émission)
- EN55103-2 : Susceptibilité électromagnétique (immunité)

Ce produit est conçu pour une utilisation dans les environnements électromagnétiques suivants :

E1 (résidentiel), E2 (commercial et industrie légère), E3 (extérieur urbain) et E4 (environnement EMC contrôlé, par ex. studio de télévision).

WARNUNG

Um Feuergefahr und die Gefahr eines elektrischen Schlages zu vermeiden, darf das Gerät weder Regen noch Feuchtigkeit ausgesetzt werden.

Um einen elektrischen Schlag zu vermeiden, darf das Gehäuse nicht geöffnet werden. Überlassen Sie Wartungsarbeiten stets nur qualifiziertem Fachpersonal.

DIESES GERÄT MUSS GEERDET WERDEN.

Hinweis für Kunden in Europa (für CCU-TX50P)

Dieses Produkt besitzt die CE-Kennzeichnung und erfüllt sowohl die EMV-Direktive (89/336/EEC) als auch die Direktive Niederspannung (73/23/EEC) der EG-Kommission.

Die Erfüllung dieser Direktiven bedeutet Konformität mit den folgenden Europäischen Normen:

- EN60950: Produktsicherheit
- EN55103-1: Elektromagnetische Störungen (Störstrahlung)
- EN55103-2: Elektromagnetische Empfindlichkeit (Störfestigkeit)

Dieses Produkt ist für den Einsatz unter folgenden elektromagnetischen Bedingungen ausgelegt:

E1 (Wohnbereich), E2 (kommerzieller und in beschränktem Maße industrieller Bereich), E3 (Stadtbereich im Freien) und E4 (kontrollierter EMV-Bereich, z.B. Fernsehstudio).

AVVERTENZA

Per evitare il pericolo di incendi o scosse elettriche, non esporre l'apparecchio alla pioggia o all'umidità.

Per evitare il rischio di scosse elettriche, non aprire l'apparecchio. Per le riparazioni rivolgersi esclusivamente a personale qualificato.

QUESTO APPARECCHIO DEVE ESSERE MESSO A TERRA.

Per i clienti in Europa (per CCU-TX50P)

Questo prodotto recante il marchio CE è conforme sia alla direttiva sulla compatibilità elettromagnetica (EMC) (89/336/CEE) che alla direttiva sulle basse tensioni (73/23/CEE) emesse dalla Commissione della Comunità Europea.

La conformità a queste direttive implica la conformità alle seguenti normative europee:

- EN60950: Sicurezza dei prodotti
- EN55103-1: Interferenza elettromagnetica (Emissione)
- EN55103-2: Sensibilità ai disturbi elettromagnetici (Immunità)

Questo prodotto è destinato all'uso nei seguenti ambienti elettromagnetici:

E1 (residenziale), E2 (commerciali e industriali leggeri), E3 (esterni urbani) e E4 (ambienti EMC controllati, ad esempio studi televisivi).

Table of Contents

Overview	6
Using the CD-ROM Manual	6
CD-ROM System Requirements	6
Preparations	6
Reading the Manual in the CD-ROM	6
Function and Location of Parts and Controls	8
Front panel	8
Rear panel	12
Connecting the CCU-TX50/50P to the Video	
Camera	15
Notes on connections	15
Self-Diagnostics	16
Entering the Self-diagnostics Mode	16
Settings of the Camera	16
Status Display of the Unit	16
Self-diagnostics of the Camera System	17
Results of the Self-diagnosis of the Internal Boards of the Unit	17
Diagnostics Page of the Camera	19
Exiting the Self-diagnostic Mode	19
When an Error Occurs	19
Notes on Use	20
Specifications	20
General	20
Input signals	20
Output signals	20
Camera input/output signals	21
Supplied accessories	21
Optional accessories	21

Overview

The CCU-TX50/50P is a camera control unit that connects to DXC-D50 Series Color Video Cameras via the CA-TX50/50P Camera Adaptor.

Features of this unit are described below.

Full-featured signal transfer functions

- The CCU-TX50/50P is able to transfer wide band component video signals.
- The maximum triaxial cable length that can be used to connect this unit to a camera adaptor is max. 750 m (when using a Belden ϕ 8.5 mm cable) or 1125 m (when using a Belden ϕ 13.2 mm cable).
- Transfer functions are provided for the following signals.
Return video, teleprompter signal, microphone audio, program audio, red tally and green tally signals
- An intercom system is also provided.

Flexibly adaptable camera control functions

- The camera control panel mounted on the front panel of the unit enables video camera operations to be controlled from the unit.
- When the RCP-D50 remote control panel is connected to the rear panel of the unit, the video camera operation can be controlled from both the remote control panel and the front panel of the unit.

Wide array of input/output signals

The input and output connectors provided for the CCU-TX50/50P include those for outputting such signals as a composite video signal (VBS), component video signals (switchable to RGB), SDI signals, and video signals for video and waveform monitors, for inputting a reference signal for external synchronization.

Status and self-diagnostics display on the picture monitor

You can check all sorts of settings of the unit and the results of self-diagnoses of internal boards on the monitor connected to the PIX connector on the rear panel.

Rack mountable

Two CCU-TX50/50P units can be installed side by side in the optional RMM-301 Rack Mount Bracket.

Using the CD-ROM Manual

The supplied CD-ROM disc includes the operating instructions for the CA-TX50/50P and CCU-TX50/50P (Japanese, English, French, German and Italian versions).

CD-ROM System Requirements

The following are required to access the supplied CD-ROM disc.

- Computer: PC with Intel Pentium CPU Installed
memory: 64 MB or more
CD-ROM drive: \times 8 or faster
- Monitor: Monitor supporting resolution of 800 \times 600 or higher
- OS: Microsoft Windows Millennium Edition, Windows 2000 Service Pack 2, Windows XP Professional or Home Edition

When these requirements are not met, access to the CD-ROM disc may be slow, or not possible at all.

Preparations

The Adobe Acrobat Reader Version 4.0 or later or the Adobe Reader Version 6.0 or later must be installed on your computer in order to use the operating instructions contained in the CD-ROM disc.

Note

If Adobe Acrobat Reader or Adobe Reader is not installed, it may be downloaded from the following URL:

<http://www.adobe.com/>

Reading the Manual in the CD-ROM

To read the operating instructions contained in the CD-ROM disc, do the following.

- 1 Insert the supplied CD-ROM disc into your CD-ROM drive.
A cover page appears automatically in your browser. If it does not appear automatically in the browser, double click the [index.htm] file on the CD-ROM disc.
- 2 Select and click the operating instructions that you want to read.
A PDF file of the operating instructions opens.

Note

If you lose the CD-ROM disc or become unable to read its content, for example because of a hardware failure, contact a Sony service representative.

- Intel and Pentium are registered trademarks of Intel Corporation or its subsidiaries in the United States and other countries.
- Adobe, Acrobat and Adobe Reader are trademarks of Adobe Systems Incorporated in the United States and/or other countries.

Function and Location of Parts and Controls

Front panel

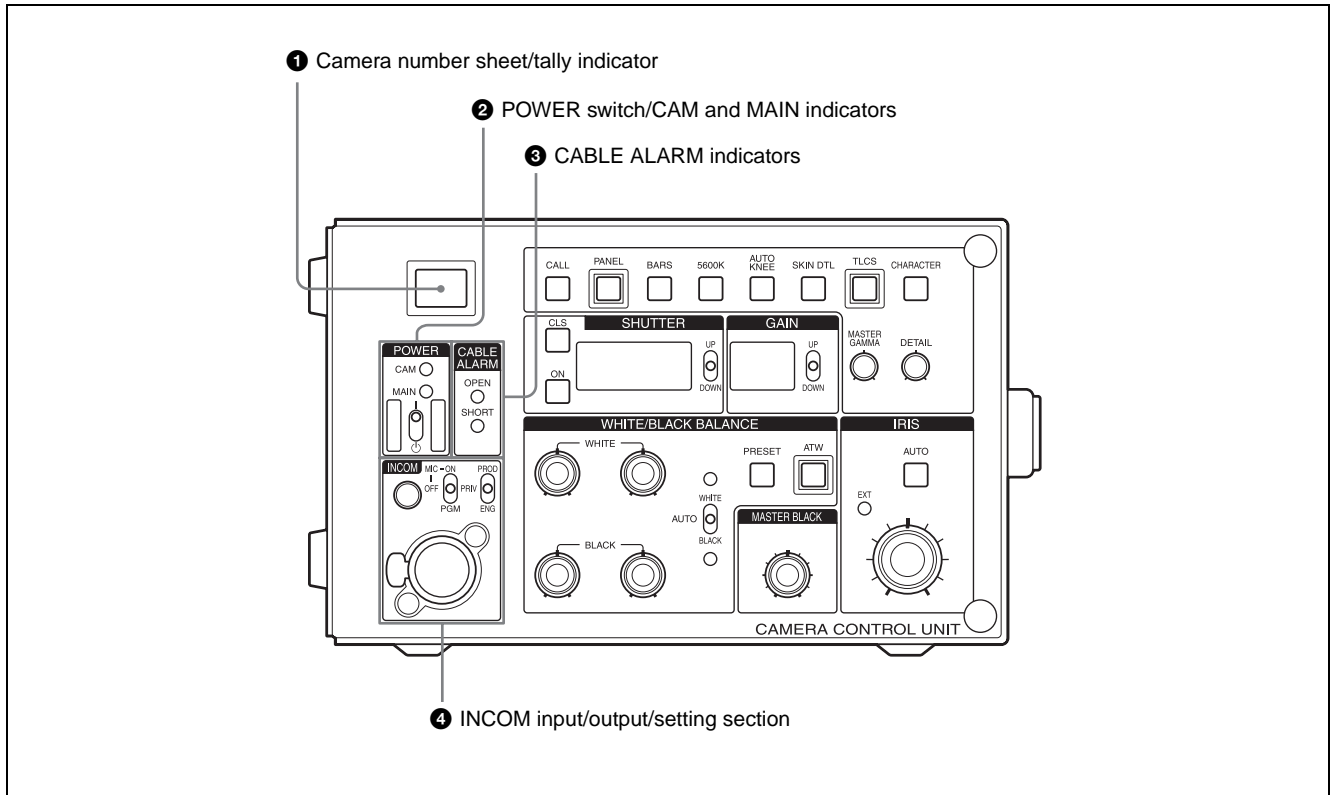

1 Camera number sheet/tally indicator

Lights red when the red tally signal is input (e.g. when the video signal from the video camera connected to the CCU-TX50/50P goes on air). When the CALL button on the unit or RCP-D50 remote control panel is pressed, the indicator lights red if it is not lit, and goes off if it is lit.

The indicator lights green when the green tally signal is input.

Attach the supplied number sheet here to indicate the camera number.

2 POWER switch/CAM (camera) and MAIN indicators

The POWER switch turns on or off the power supply to the entire camera system, including the CCU-TX50/50P, the video camera, and the remote control unit connected to the REMOTE connector on the CCU-TX50/50P.

The MAIN and CAM indicators light when the POWER switch is turned on.

The CAM indicator goes off when the power is turned off by the CAM PW button on the remote control panel.

Note

If the fan in the CCU-TX50/50P stops, the MAIN indicator will flash simultaneously to warn you of the abnormal condition. If this occurs, turn the POWER switch off immediately and contact Sony service personnel.

3 CABLE ALARM indicators

OPEN: Lights when no triaxial cable is connected to the CAMERA connector on the rear panel of the CCU-TX50/50P, or when the load current is extremely low even when a camera cable is connected.

SHORT: Lights when there is a current overflow in the triaxial cable.

4 INCOM (intercom) input/output/setting section

INCOM (intercom) connector (XLR, 5-pin)

Connects a headset.

INCOM level control

Adjusts the input level of the headset.

MIC/PGM (program audio) switch

ON: Turns on the headset microphone.

OFF: Turns off the headset microphone.

PGM: Outputs the program audio. When this position is selected, the INCOM level control adjusts input level of the program audio.

INCOM selector

Selects the pathway of intercom signals output/input through the INCOM connector.

PROD: Producer line.

PRIV: Producer line and engineer line are cut off and communication is possible only between the CCU-TX50/50P and the camera connected to the rear panel of the CCU-TX50/50P.

ENG: Engineer line.

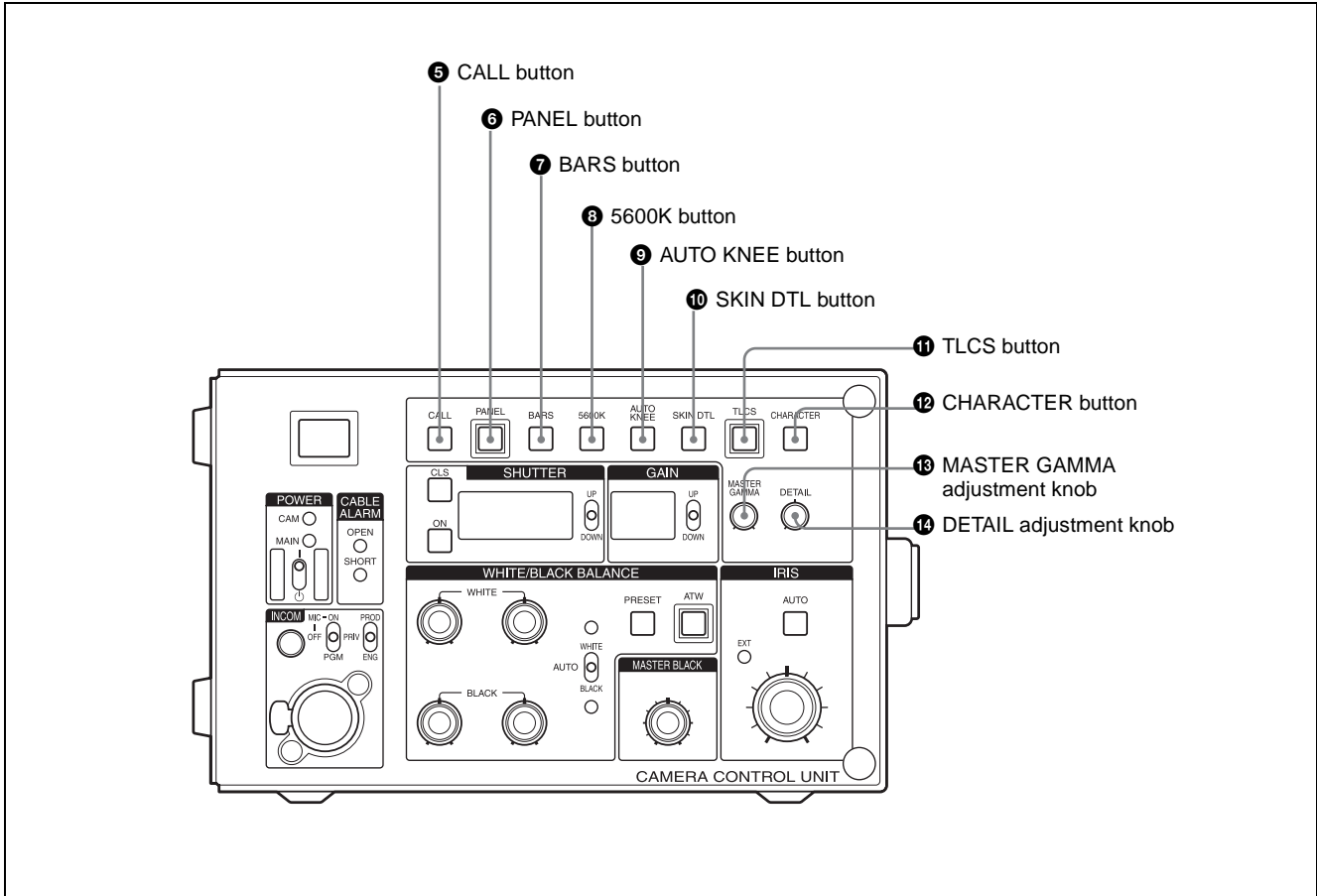

5 CALL button

When you press this button, the TALLY indicator on the camera adaptor lights. The tally indicator on the unit also lights red when you press this button, and goes off if the CALL button is pressed while it is lit.

6 PANEL button

When the RCP-D50 camera control panel is connected, press this button to light it up so you can select the device which controls the camera. The unit can control the camera when this button is lit.

7 BARS button

Press this button (which lights up when pressed) to send the color bar signal to the monitor. The color bars then appear on the monitor.

8 5600K button

Press this button (which lights up when pressed) to convert the color temperature electronically instead of using the optical filter.

9 AUTO KNEE button

Press this button (which lights up when pressed) to activate the automatic knee function which optimizes the input signal compensation.

10 SKIN DTL button

Use this button to turn the skin detail correction function on or off. Press this button (which lights up when pressed) to set the skin detail correction function to on. To set this function to off, press this button again.

11 TLCS (total level control system) button

Press this button to turn the total level control system on or off. When this button is lit, it is turned on, and settings

made with the GAIN control section and SHUTTER setting section are ignored.

12 CHARACTER button

Press this button (which lights up when pressed) to display the self-diagnostics screen on the picture monitor. Each time you press this button, the screen

changes to the next page. When this button is not lit, the self-diagnostics screens are not displayed.

13 MASTER GAMMA adjustment knob

Use this knob to adjust the gamma curve.

14 DETAIL adjustment knob

Use this knob to adjust the detail level.

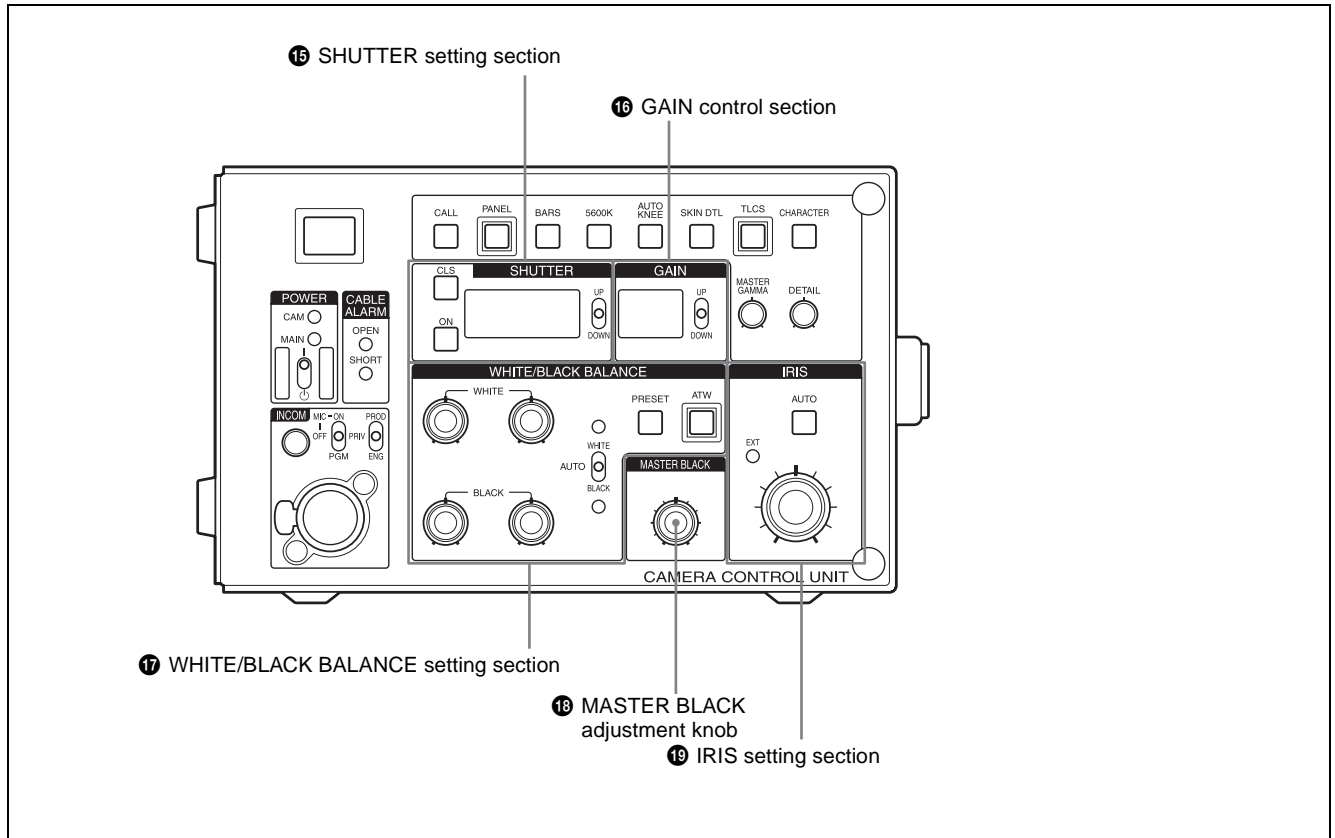

15 SHUTTER setting section

Selects a shutter setting.

Note

This section does not function when the TLCS button is on.

CLS button

Press this button (which lights up when pressed) to activate the clear scan function.

ON button

Press this button (which lights up when pressed) to activate the normal shutter function.

UP/DOWN selector

When the CLS button lights: The clear scan frequency is increased, each time you press this selector to the UP position. The clear scan frequency is reduced, each time you press this selector to the DOWN position.

When the ON button lights: The shutter speed is increased, each time this selector to the UP position. The shutter speed is reduced, each time you press this selector to the DOWN position.

Display

Displays the clear scan frequency when the CLS button lights, or the shutter speed when the ON button lights.

16 GAIN control section

Adjusts the gain to obtain the most appropriate level for the lighting condition.

UP/DOWN selector

The gain is increased, each time you press this selector to the UP position. The gain is decreased, each time you press this selector to the DOWN position.

Display

Displays the gain values in decibel units.

17 WHITE/BLACK BALANCE setting section

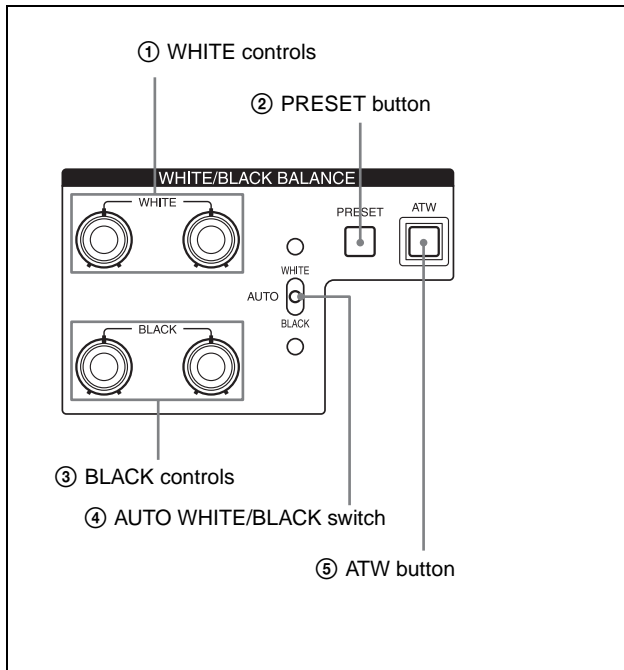

① WHITE (white balance manual adjustment) controls

Turn these controls to manually adjust the white balance. The left-hand control adjusts the R signal level and the right-hand control adjusts the B signal level.

② PRESET button

Press this button (which lights up when pressed) to set the white balance to the preset value. When this button is lit, the operation of the AUTO WHITE section of the AUTO WHITE/BLACK switch is ignored.

③ BLACK (black balance manual adjustment) controls

Turn these controls to manually adjust the black balance. The left-hand control adjusts the R signal level and the right-hand control adjusts the B signal level.

④ AUTO WHITE/BLACK (white balance/black balance automatic adjustment) switch

Activates the automatic adjustment of the white balance and black balance.

WHITE: Adjusts the white balance automatically one time when the switch is set to this position.

BLACK: Adjusts the black balance automatically one time when the switch is set to this position.

⑤ ATW (auto tracing white balance) button

Press this button (which lights up when pressed) to have the white balance adjusted automatically when lighting conditions change.

18 MASTER BLACK adjustment knob

Adjusts the master black levels of the R, G, and B signals simultaneously. The click position of the knob provides a typical setting.

19 IRIS setting section

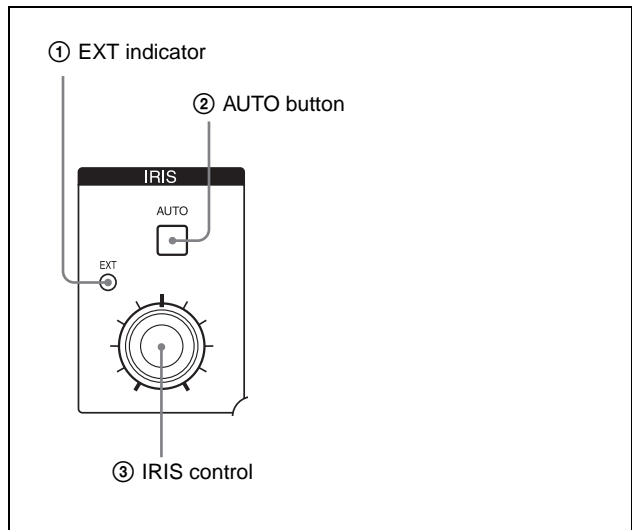

① EXT (extender) indicator

Lights when a lens extender is being used on the video camera.

② AUTO button

Press this button (which lights up when pressed) for automatic adjustment of the iris. This button lights when the automatic adjustment is in progress. Press this button again to manually adjust the iris.

③ IRIS control

Adjusts the iris manually when the AUTO button is set to off. When the AUTO button lights, you can turn this control to change the reference value for the automatic iris adjustment.

Rear panel

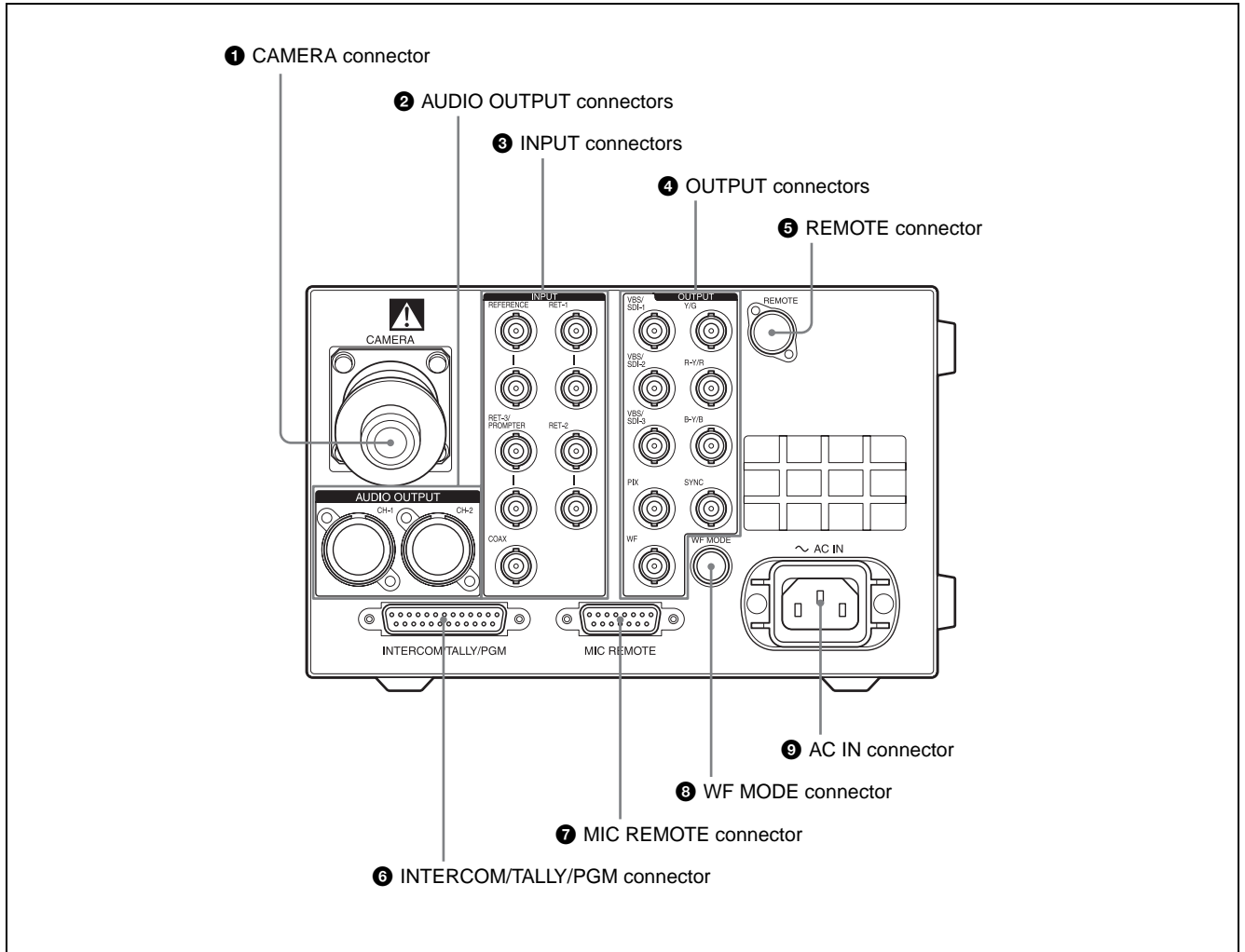

1 CAMERA connector (triaxial connector)
Connects to the CA-TX50/50P Camera Adaptor attached to the DXC-D50 Color Video Camera using a triaxial cable.

Caution

Do NOT use a defective triaxial cable. The inner sheath of a triaxial cable is used for power supply and the outer sheath for safety ground. For your safety, do NOT use a triaxial cable whose inner and outer sheaths are short-circuited. Use of such a cable will cause electric shock.

2 AUDIO OUTPUT connectors (XLR, 3-pin)
Supply audio signals from the video camera.

3 INPUT connectors
The two connectors of each pair are loop-through connectors. When the upper connector is used and no connection is made to the lower connector, the upper

connector is terminated automatically with an impedance of 75 ohms.

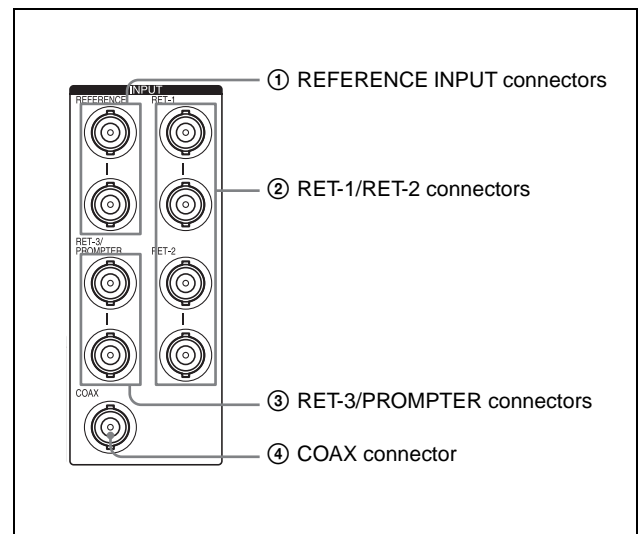

① **REFERENCE INPUT connectors (BNC type)**
Accept reference signals (black burst signal) for external synchronization.

② **RET-1/RET-2 (return video signal 1/2) connectors (BNC type)**
Accept return video signals from two different systems.

For details on the selection of RET-1 and RET-2, refer to Operation Manual that came with the camera or camera adaptor.

③ **RET-3/PROMPTER (return video signal 3/ prompter) connectors (BNC type)**
Accept a return video signal or a teleprompter signal.

For details on the selection of RET-3, refer to Operation Manual that came with the camera or camera adaptor.

To set this connector to the PROMPTER output, it is required to change the setting in the internal board.

For details on the internal boards, consult your nearest Sony dealer.

④ **COAX (coaxial) connector (BNC type)**
Accepts and supplies signals from/to the video camera using a coaxial cable. Power is not supplied to the camera and a camera adaptor through this connector.

To use this connector, it is required to change the setting of the internal board. For details, consult your nearest Sony dealer.

④ OUTPUT connectors

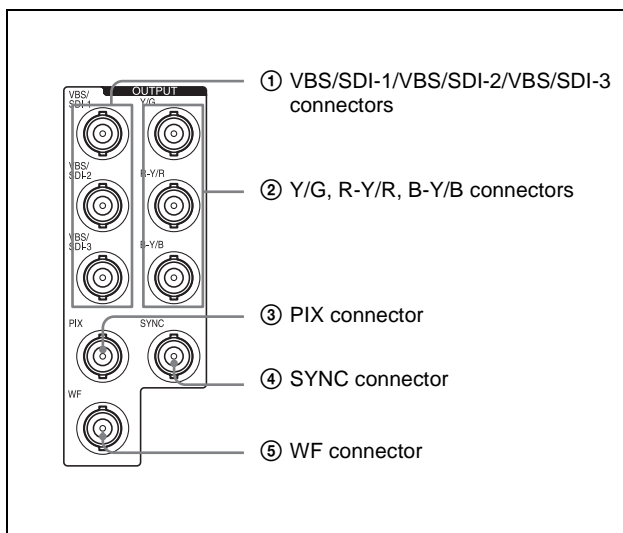

① **VBS/SDI-1/VBS/SDI-2/VBS/SDI-3 (composite video signal 1/2/3 output) connectors (BNC type)**
Supply the signal from the video camera in composite or SDI format.

Use the switch on the internal board to select the signals to be output.

For details on the internal boards, consult your nearest Sony dealer.

② **Y/G, R-Y/R, B-Y/B (component video signal / RGB output) connectors (BNC type)**

Supply the component signals or the R, G, and B signals for the chroma keyer from each connector.

Use the switch on the internal board to select the signals to be output.

For details on the internal boards, consult your nearest Sony dealer.

③ **PIX (picture monitor output) connector (BNC type)**

Supplies a video signal or video and character signals together to a picture monitor.

When using the RCP-D50 Remote Control Panel, you can select the signal output from the PIX connector using the MONITOR SELECT button on the menu of the RCP-D50. When the signal output from the PIX connector changes, the waveform output on the waveform monitor also changes.

④ **SYNC connector**

Connect to the synchronous signal input connector on a waveform monitor or picture monitor

⑤ **WF (waveform monitor output) connector (BNC type)**

Supplies a video signal to a waveform monitor.

When using the RCP-D50 Remote Control Panel, you can select the signal output from the PIX connector using the MONITOR SELECT button on the menu of the RCP-D50. Changing the signal output from the WF connector simultaneously changes the picture on the picture monitor.

⑥ **REMOTE (RCP (remote control panel) remote) connector (10-pin)**

Connects to the RCP-D50 Series Remote Control Panel with an optional CCA-7 connecting cable to transmit/receive control signals.

⑦ **INTERCOM/TALLY/PGM (program audio) connector (D-sub, 25-pin)**

Inputs/outputs intercom, tally, or program audio signals.

Connects to an intercom, tally, or program audio connector of an intercom system.

⑧ **MIC REMOTE (microphone remote control) connector (D-sub, 15-pin)**

Connects to an external control unit such as an audio mixer. With the connected unit, you can set the microphone input level of the video camera to -60, -50, -40, -30, or -20 dB.

⑨ **WF MODE (waveform monitor mode) connector (4-pin)**

Connects to the corresponding connector on a waveform monitor to allow the sequential monitoring of signals.

9 AC IN (AC power input) connector

Connects to an AC power source using the supplied AC power cord. Secure the power cord to the CCU-TX50/50P using the supplied plug holder.

Connecting the CCU-TX50/50P to the Video Camera

When connecting a CCU-TX50/50P to a DXC-D50 Color Video Camera, you must first attach the CA-TX50/50P Camera Adaptor to the video camera.

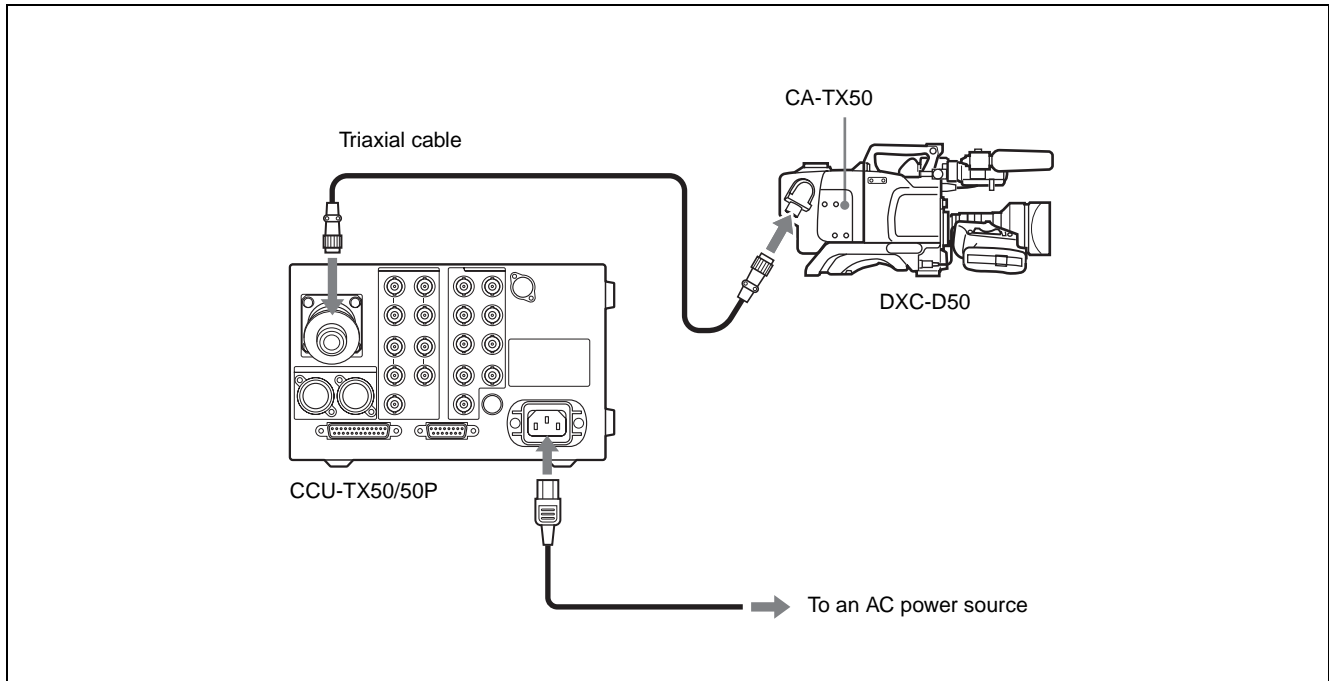

Notes on connections

Triaxial cable

The triaxial cable should never be connected to or disconnected from the CCU-TX50/50P when the power is turned on. Always turn the unit off first.

Video camera

Some switches or controls on the video camera may not work when the camera is connected to the CCU-TX50/50P.

For details, refer to Operation Manuals of the video camera and the camera adaptor.

Self-Diagnostics

The unit allows you to display the status of the unit and the results of a self-diagnosis of the internal boards of the unit on the screen of a picture monitor connected to the unit.

You can display the following status items:

- Settings of the camera
- Status display of the unit
- Results of a self-diagnosis of the internal boards
- Self-diagnostics of the camera system

Entering the Self-diagnostics Mode

The unit enters the self-diagnostics mode, by pressing the CHARACTER button on the front panel of the unit. Each time you press the CHARACTER button, the display changes.

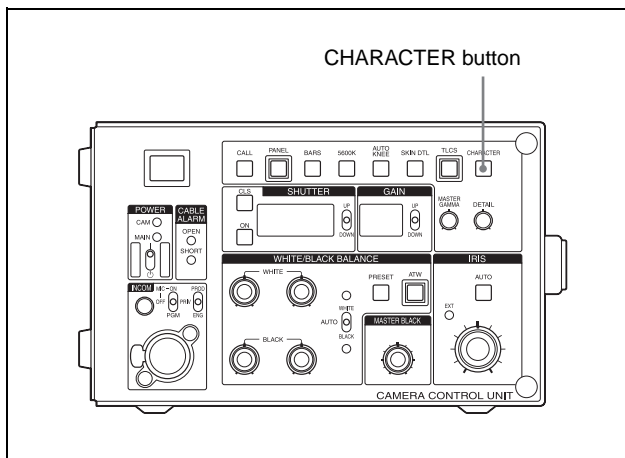

Settings of the Camera

The settings and operations status of the camera are displayed.

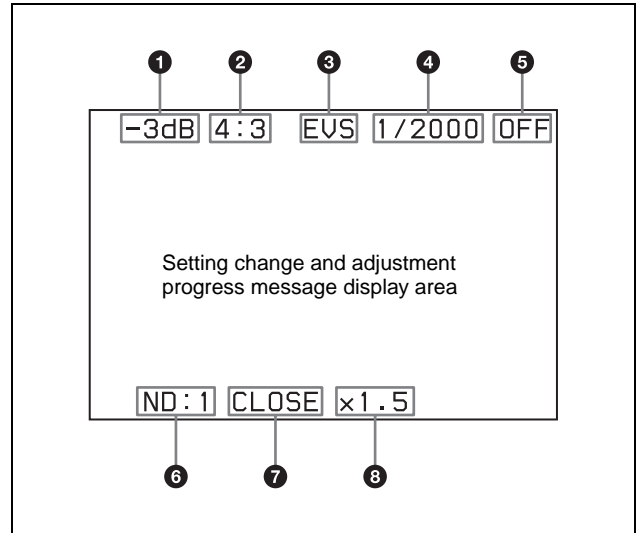

- 1 Master gain
- 2 “4:3” is displayed when the images recorded in 16:9 format are output after converted to the images of the 4:3 mode.
- 3 “EVS” is displayed when EVS of the electrical shutter is on.
- 4 Shows the shutter speed currently selected.
- 5 Shows the on/off setting of the shutter.
- 6 Shows the type of ND filter currently selected.
- 7 Shows the F-stop (iris setting) of the lens.
- 8 EX is displayed when a lens extender is used.

Status Display of the Unit

Press the CHARACTER button when the screen of the camera settings is displayed. The status of the unit is displayed.

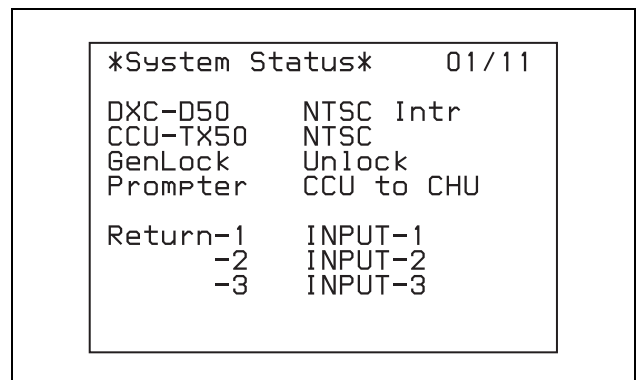

DXC-D50: Model name and format of the connected camera

CCU-TX50: Model name and format of the camera control unit connected.

Genlock: External reference signal and its status (lock/unlock)

Prompter: Transmission direction of the prompter line

Return 1 to 3: Return video signal input status

Self-diagnostics of the Camera System

Press the CHARACTER button when the status display of the unit is displayed. Page 1 of the self-diagnostics display is displayed.

The results of a self-diagnosis of the camera system are displayed spread over three pages.

Page 1

```
*System Diag 1/3* 02/11
  TRIAX TYPE Wide
          Cable Connect
          Comp. Auto
          Step 2(550m)
  Fan Power OK
  Timer 10H
  CCU Power AC OK
```

TRIAX TYPE: Type of Triaxial circuit

TRIAX Cable: Triaxial cable connection status (connected/disconnected)

TRIAX Comp.: Cable compensation type selected for the triaxial cable (automatic/manual)

TRIAX Step: Compensation step of the triaxial cable (step indication in the circuit) (The cable length may not be displayed correctly.)

Fan power: Fan status in the CCU power block

Timer: Power up time to devices connected

CCU Power: Status of the CCU power supply

Page 2

```
*System Diag 2/3* 03/11
  CAMERA Cable Open
          Data ----
          Power OFF
          Tone ----
  RCP Cable Connect
   Data OK
   Power OK
```

CAMERA cable: Camera cable connection status (connected/shorted)

CAMERA Data: Camera data transmission status

CAMERA Power: Status of the power supply to a camera

CAMERA Tone: Camera ID tone status

RCP cable: Connection status of the REMOTE connector

RCP Data: Data transmission status of the REMOTE connector

RCP Power: REMOTE connector power supply status

Page 3

```
*System Diag 3/3* 04/11
  Intercom
  CCU Private
  CAMERA CH1 ENG
           MIC ON
  CHU MIC Gain Local
         CH1 60dB
         CH2 60dB
```

Intercom CCU: CCU intercom selection (system/private)

Intercom CAMERA CH1: Status of intercom 1 of a camera (producer line/engineer line)

CHU MIC Gain: Gain and control status of the microphone circuit

Results of the Self-diagnosis of the Internal Boards of the Unit

Press the CHARACTER button when page 3 is displayed. Page 1 of the results of the self-diagnosis of the internal boards is displayed.

Each time you press the CHARACTER button, another page of results is displayed in turn.

DM board

```

*DM Diag*                05/11

CAM Video Y      OK
                  R-Y OK
                  B-Y OK
Skin Gate        OK
TRIAX Comp.     Auto
                Step 2(550m)

Power            OK
    
```

CAM Video: Reception status of the video signals from the camera.

Skin Gate: Reception status of the Skin gate signal from the camera

TRIAX Comp.: Cable compensation type selected for the triaxial cable (automatic/manual)

TRIAX Step: Compensation step of the triaxial cable (step indication in the circuit) (The cable length may not be displayed correctly.)

Power: DM board power supply status

TR board

```

*TR Diag*                06/12

Prompter Remote
                  CCU to CHU
                  No Video
Tone Detect
Incom OK
CHU Data OK

Power            OK
    
```

Prompter: Setting status of the prompter line

Tone: Tone signal status

Incom: Demodulating status of the intercom line

CHU Data: Data reception status from the camera

Power: Power supply status of the TR board

AT board

```

*AT Diag*                07/11

Reference Remote
Gen Lock  Unlock
BATT Volt 2.5V
CCU Mode  Normal

PLD Config OK
CCU Power DC OK
    
```

Reference: Operation mode of the phase adjustment

Gen Lock: Locking status

BATT Volt: Voltage of the coin battery supplied with the AT board

CCU Mode: Operation mode of the CCU

PLD Config.: Configuration result status of the PLD mounted on the AT board

CCU Power: CCU power supply type (AC/DC) and power supply status

AU board

```

*AU Diag*                08/11

CAMERA
MIC OFF
LINE ENG
CCU-FRONT
MIC OFF
LINE PROG

POWER OK
    
```

CAMERA MIC: Input status of the camera microphone (on/off)

CAMERA LINE: Pathway of the intercom signal of the camera (ENG/PROD/PRIV)

CCU FRONT MIC: Input status of the unit's microphone (on/off)

CCU FRONT LINE: Pathway of the connection of the intercom signal of the unit (ENG/PROD/PRIV)

POWER: Power supply status of the AU board

IV board

```
*IV Diag*           09/11
Return   Local
CH-1    INPUT-1
CH-2    INPUT-2
CH-3    INPUT-3
Signal  Detect

Rear-CN   OK
PLD Config OK
Power     OK
```

Return: Setting status of the return signal input connectors to the return channels from 1 to 3

Return Signal: Status of the return video input signal

Rear CN: Power supply status of the CN board on the rear

PLD Config: Configuration completion status of the PLD mounted on the IV board

Power: Power supply status of the IV board

EN board

```
*EN Diag*           10/11
Component  YCd Sync
Composite
Out-1      VBS
Out-2      SDI
Out-3      SDI-MON
Setup      ON
Rear-VDA   NG
PLD Config OK
Power      OK
```

Component: Setting status of the component output signal from the OUTPUT connector and status of the sync signal added to the component Y/G output signal from the OUTPUT connector

Composite Out-1: Signal type from composite output connector 1 (VBS/SDI)

Composite Out-2: Signal type from composite output connector 2 (VBS/SDI)

Composite Out-3: Signal type from composite output connector 3 (VBS/SDI)

Composite Setup: Setup settings to be added to the VBS signal

Rear VDA: Power supply status of the VDA board on the rear

PLD Config: Configuration completion status of the PLD mounted on the EN board

Power: Power supply status of the EN board

Diagnostics Page of the Camera

```
*CAMERA Diag*      11/11
[ NG BOARD ]
DM   AT
```

The results of the diagnosis of each board of the camera are displayed.

Exiting the Self-diagnostic Mode

Display the last “ROM Version” page, and then press the CHARACTER button again.

When an Error Occurs

The error message is displayed on the picture monitor. In such a case, display the self-diagnostics page corresponding to the board where the error has occurred by pressing the CHARACTER button.

Notes on Use

Use and storage locations

Avoid using or storing the unit in the following places:

- Where it is subject to extremes of temperature (operating temperature: +5°C to +40°C (41°F to 104°F)).
Note that in summer the temperature in a car with the windows closed can reach 50°C (122°F).
- Very damp or dusty places.
- Where rain is likely to reach the unit.
- Places subject to severe vibration.
- Near strong magnetic fields

Near transmitting stations generating strong radio waves.

Avoid violent impacts

Dropping the unit, or otherwise imparting a violent shock to it, is likely to cause it to malfunction.

Do not cover with cloth

While the unit is in operation, do not cover it with a cloth or other material. This can cause the temperature to rise, leading to a malfunction.

After use

Turn the POWER switches on the unit and camera control unit off.

Care

If the body of the unit is dirty, wipe it with a dry cloth. For severe dirt, use a soft cloth steeped in a small amount of neutral detergent, then wipe dry. Do not use volatile solvents such as alcohol or thinners, as these may damage the finish.

Specifications

General

Power consumption	100 - 240 V AC, 50/60 Hz, maximum 1.3 A
Peak inrush current	(1) Power ON, current probe method: 50 A (240V) (2) Hot switching inrush current, measured in accordance with European standard EN55103-1: 10 A (230V)
Cable length	Maximum 750 m (φ 8.5 mm)
Operating temperature	+5°C to +40°C (41°F to 104°F)
Dimensions	200 × 124 × 365 mm (8 × 5 × 13 7/8 in.) (w / h / d) not including projecting parts
Mass	Approx. 5.5 kg

Input signals

REFERENCE	BNC type (loop-through) VBS/BS, 1.0 V _{p-p} , 75 ohms automatic terminated
RET-1/2/3 ¹⁾	BNC type (1 each, loop-through) VBS, 1.0 V _{p-p} , 75 ohms automatic terminated
PROMPTER ¹⁾	BNC type (loop-through) VBS, 1.0 V _{p-p} , 75 ohms

1) The same signal is input to RET-3 and PROMPTER.

Output signals

VBS 1/2/3	BNC type (1 each) VBS, 1.0 V _{p-p} , 75 ohms
SDI	BNC type (3) SDI format, 270 Mbps, SMPTE 259M (CCU-TX50)/CCIR656-III (CCU- TX50P)
Y/R-Y/B-Y video ²⁾	BNC type (1 each) Y: 1.0 V _{p-p} , 75 ohms R-Y/B-Y: U.S.A. and Canada: 700 mV _{p-p} , 75 ohms Europe: 525 mV _{p-p} , 75 ohms
R/G/B video ²⁾	BNC type (1 each) 700 mV _{p-p} , 75 ohms
PIX	BNC type (1) 1.0 V _{p-p} , 75 ohms
WF	BNC type (1) NTSC: 714 mV _{p-p} , 75 ohms

	PAL: 700 mVp-p, 75 ohms
	Encoded output: 1.0 Vp-p, 75 ohms
WF MODE	4-pin (1)
AUDIO OUTPUT	XLR, 3-pin
	0 dBu/-20 dBu, balanced, 2 channels
SYNC	BNC type

2) R/G/B/and Y/R-Y/B-Y are switchable.

Camera input/output signals

CAMERA	Triax (Kings type for the U.S.A. and Canada, Fischer type for Europe)
COAX	BNC type (1), 75 ohms
REMOTE	10-pin, multi connector
INTERCOM/TALLY/PGM	D-sub, 25-pin (1)
	4W/RTS
	TALLY: 24 V DC, TTL level or contact selectable
MIC REMOTE	D-sub, 15-pin (1)
INCOM (on the front panel)	XLR, 5-pin (1)

Supplied accessories

AC power cord (1)
AC power plug holder (1)
Number plate (1 set)
Operating Instructions (1)
CD-ROM (including multi-lingual operating instructions) (1)
Warranty booklet (1)

Optional accessories

Remote Control Panel RCP-D50
Rack Mount Bracket RMM-301

Design and specifications are subject to change without notice.

